

Use Instruction

- The printer is of DIY collection. Some parts need to be assembled by customers. Take good care of every connection parts and we suggest you to fix every connection with Hot Glue / Silica Gel.
- Please do not attempt to use the machine in any way have not described in the instructions. Improper use may cause serious injuries and property damage.
- Keep the printer away from heat sources, fire, flammable and explosive materials. Please place the printer in a ventilated, cool and dust free environment.
- Please do not place the printer on unstable surfaces. The vibration of the machine will affect the printing quality.
- Use only the original power cord supplied with the printer. Please do not replace the power cord during installation. The working power supply is 110V/220V AC. The power plug must be plugged into the three holes socket with ground wire to avoid damages to components or accidents such as fire and electric shock.
- Please do not touch the nozzle, the extruder and the heating bed while operating the printer to prevent burns and personal injuries.
- Please do not wear gloves or bracelets when operating the machine in case the movable parts cause entanglement and cutting damage on human body parts.
- After printing, please clean up the material residues with tools and the remaining temperature of the nozzle. Do not touch the nozzle by hands during cleaning to prevent burns.
- Maintenance work should be regular done to keep the printer in good condition and achieve high quality prints every time. Before commencing any repair it is extremely important to turn off the printer and let it cool down. Please use dry cloth to wipe away dust and material residues, foreign objects on the printer body and guide rails. Lubricate the sliding parts, screw rods and bearing parts with grease.
- The printer is not intended for use by children under the age of 14 and by people above the age of 60. Please use this printer under the assistance and guidance to avoid personal injury.
- Self-disassembly or modification may cause damage or abnormal performance, and your machine will no longer enjoy warranty service.
- Please cut off the power supply after using.
- The recommend filament for this printer is 1.75mm PLA. We recommend to use Anet official filament.
- Get more information from the flash disk in the package. And visit our website: www.anet3d.com regularly to learn about the latest news and updates.

Notice

1. All the contents in this manual have been checked carefully. If there is any misprint or misunderstanding of them, Anet reserves the right of interpretation and amendment without prior notification.
2. The content in user manual, including products (appearance, color and size, etc) and software(UI, screen snap, etc.), are for reference only and does not constitute any form of commitment. Please be subject to the actual products.
3. All data given in this manual are theoretical values obtained by Anet internal laboratories through tests carried out under laboratory conditions. Actual performance may vary depending on variation among specific models, software versions, application usage, and environmental factors. All performance metrics are subject to the particulars of the use case.



Shenzhen Anet Technology Co., Ltd.

Add: Floor 1, 2 and B area of 3, the 4th Factory Building, Xiangli Ind. Park, No.1 Xiangli Road, North of Qinghu Road, Longhua Str., Longhua Dist., Shenzhen.
Tel: +86 755 2373 6621

Email: anet@anet3d.com

V1.2

Anet
3D PRINTER

Anet ET4

Setup Manual



Specifications

Model	ET4	Machine Net Weight	7.2±0.2Kg
Printing Technology	FDM	Standard Nozzle Diameter	0.4mm
Filament	PLA 1.75mm	Hotbed Temp	≤100°C
Machine Power	200W	Extruder Working Temp	≤250°C
Power Supply	240W	Language	English / Chinese
Printing Size	220*220*250mm	Auto Filament Dispenser	Yes
Machine Size	440*340*480mm	Filament Detection	Yes
Printing Speed	≤150mm/s (recommended speed 30-60mm/s)	Auto Leveling	Yes
Printing Resolution	±0.1mm	Resume Printing	Yes
Slice Thickness	0.1-0.3mm	Offline Print	Yes

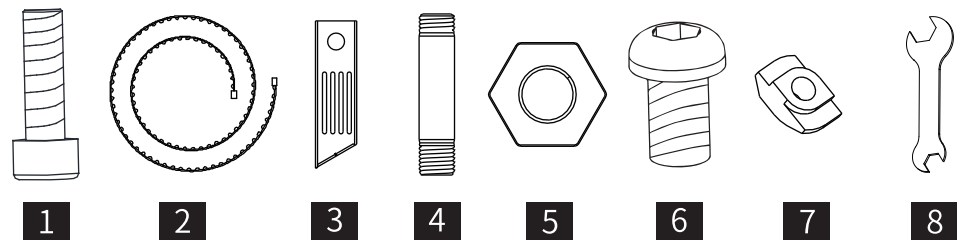

1

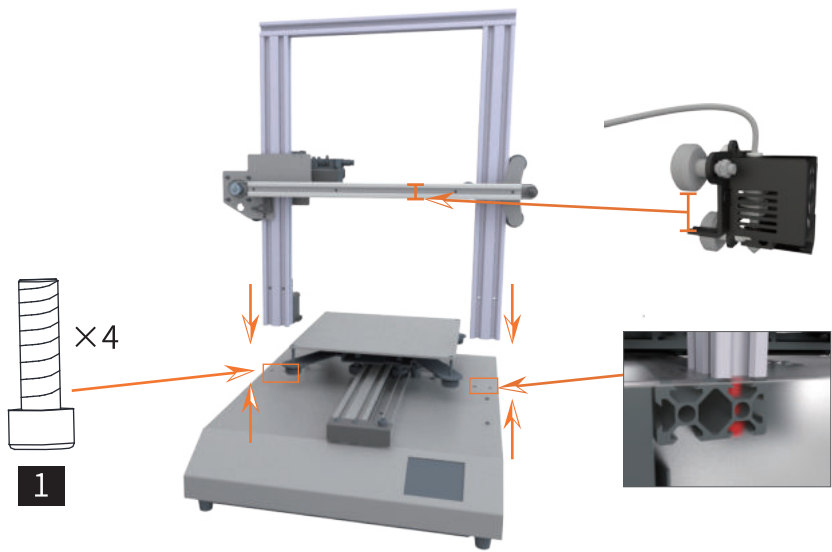

2

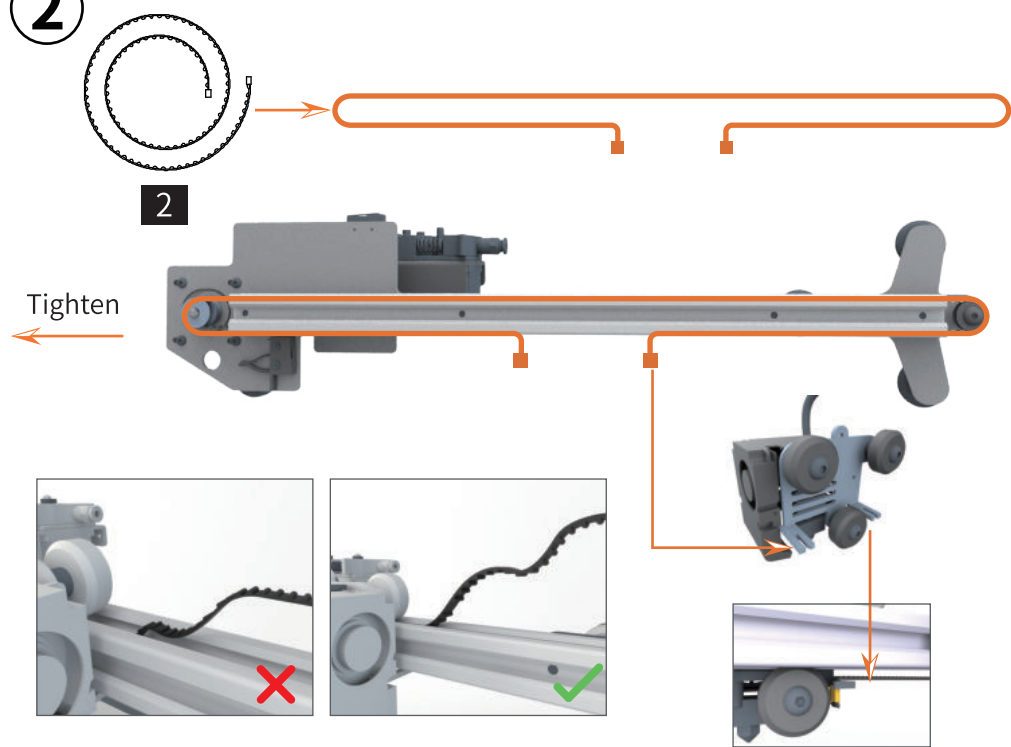

3

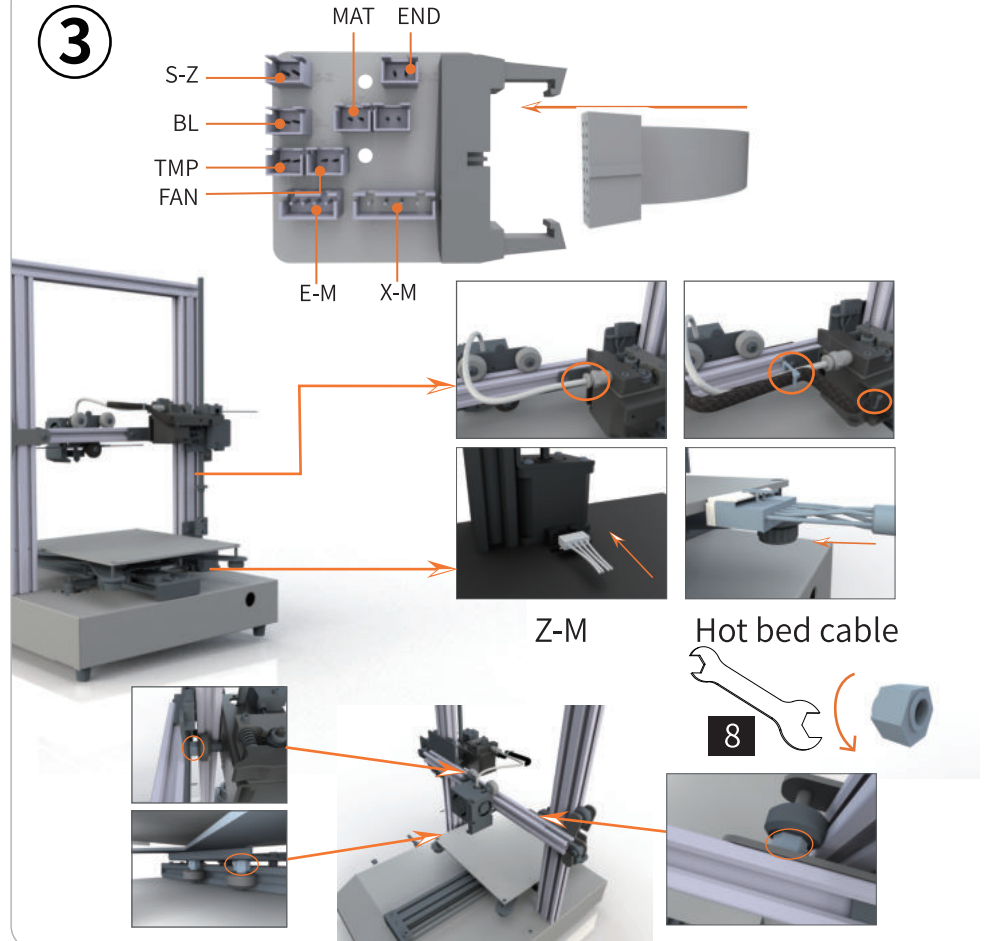

4

